

SIMBA

70x140 70x160

80x140 80x160 80x180 80x190 80x200

90x140 90x160 90x180 90x190 90x200

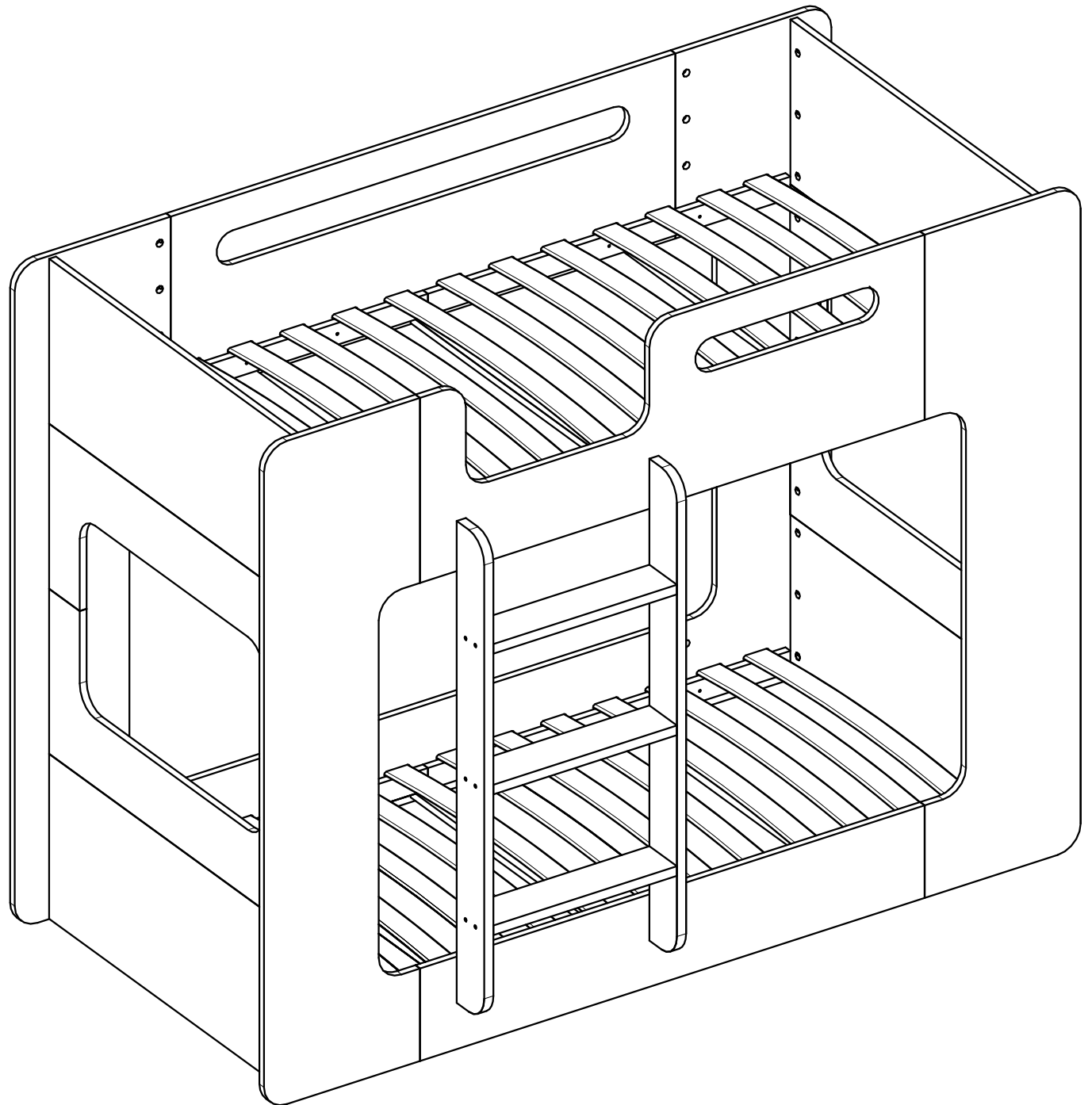

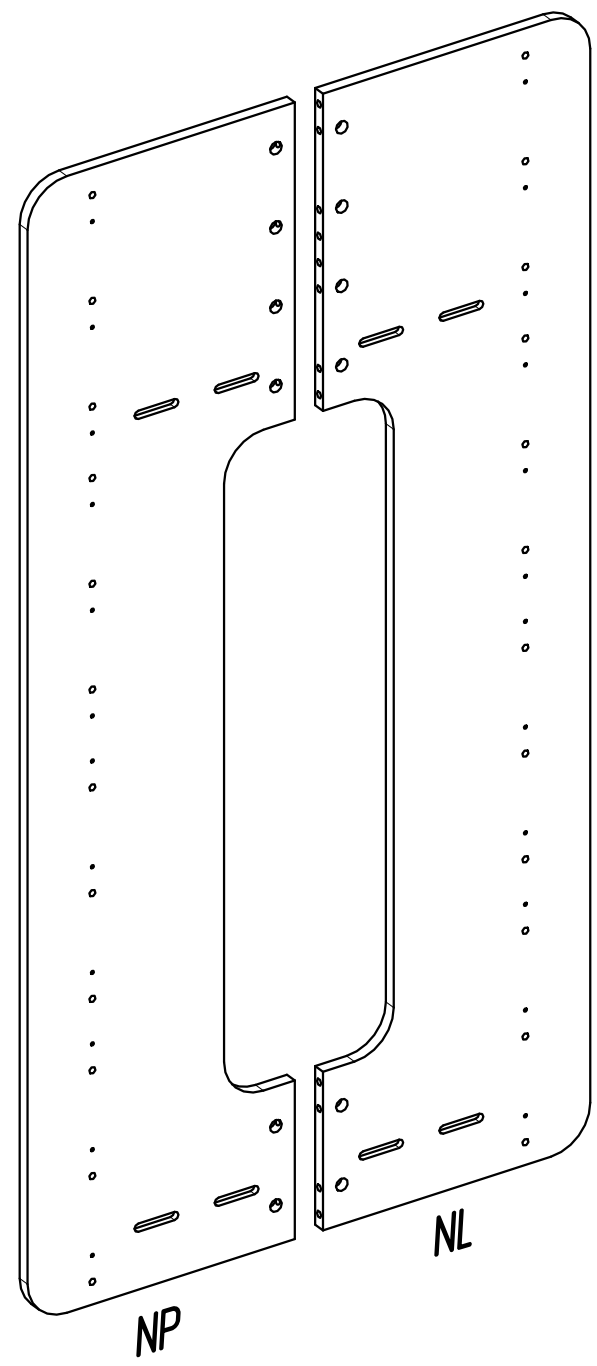
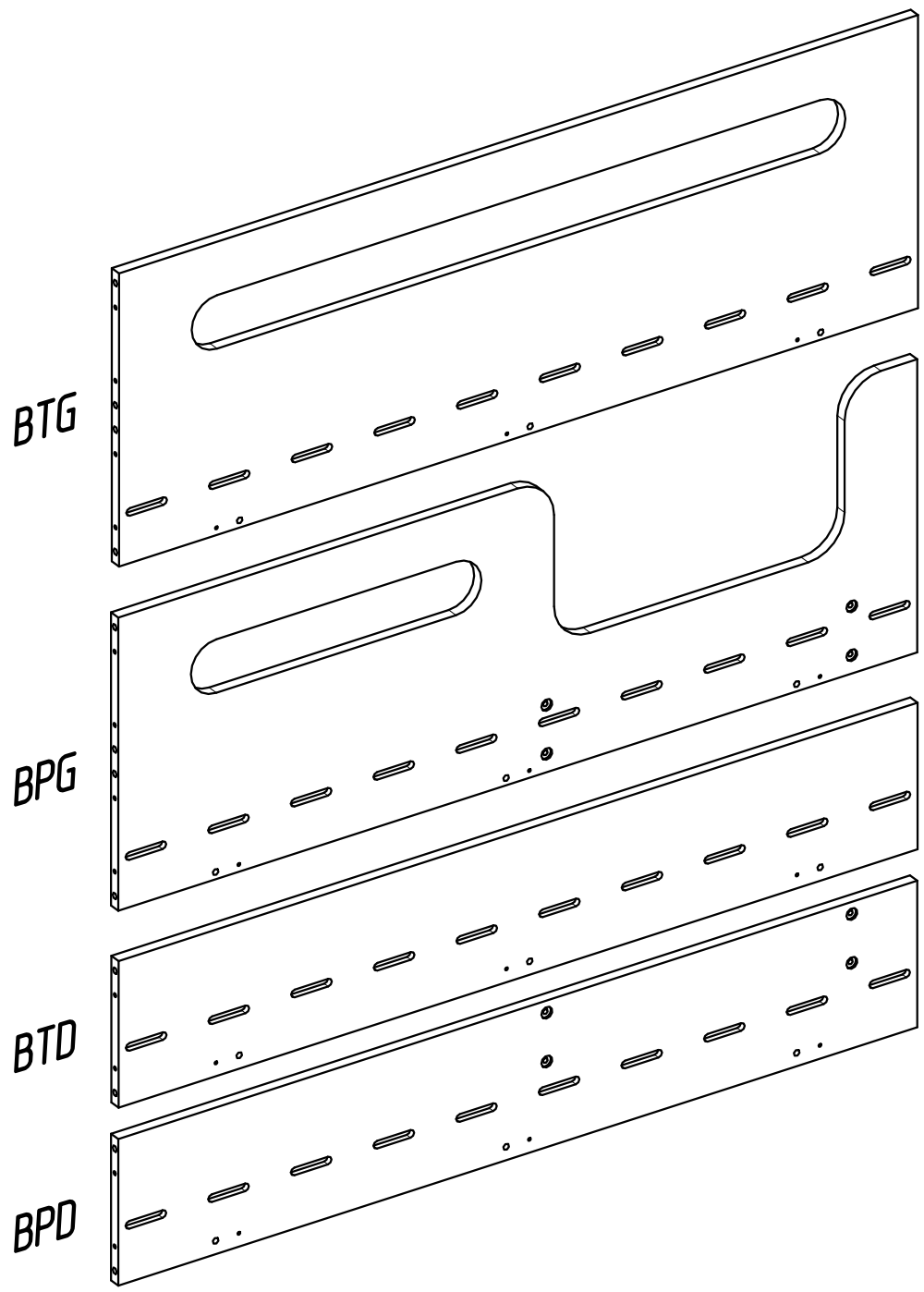

SIMBA

- BTG- x1*
- BPG- x1*
- BTD- x1*
- BPD - x1*
- NP - x2*
- NL- x2*

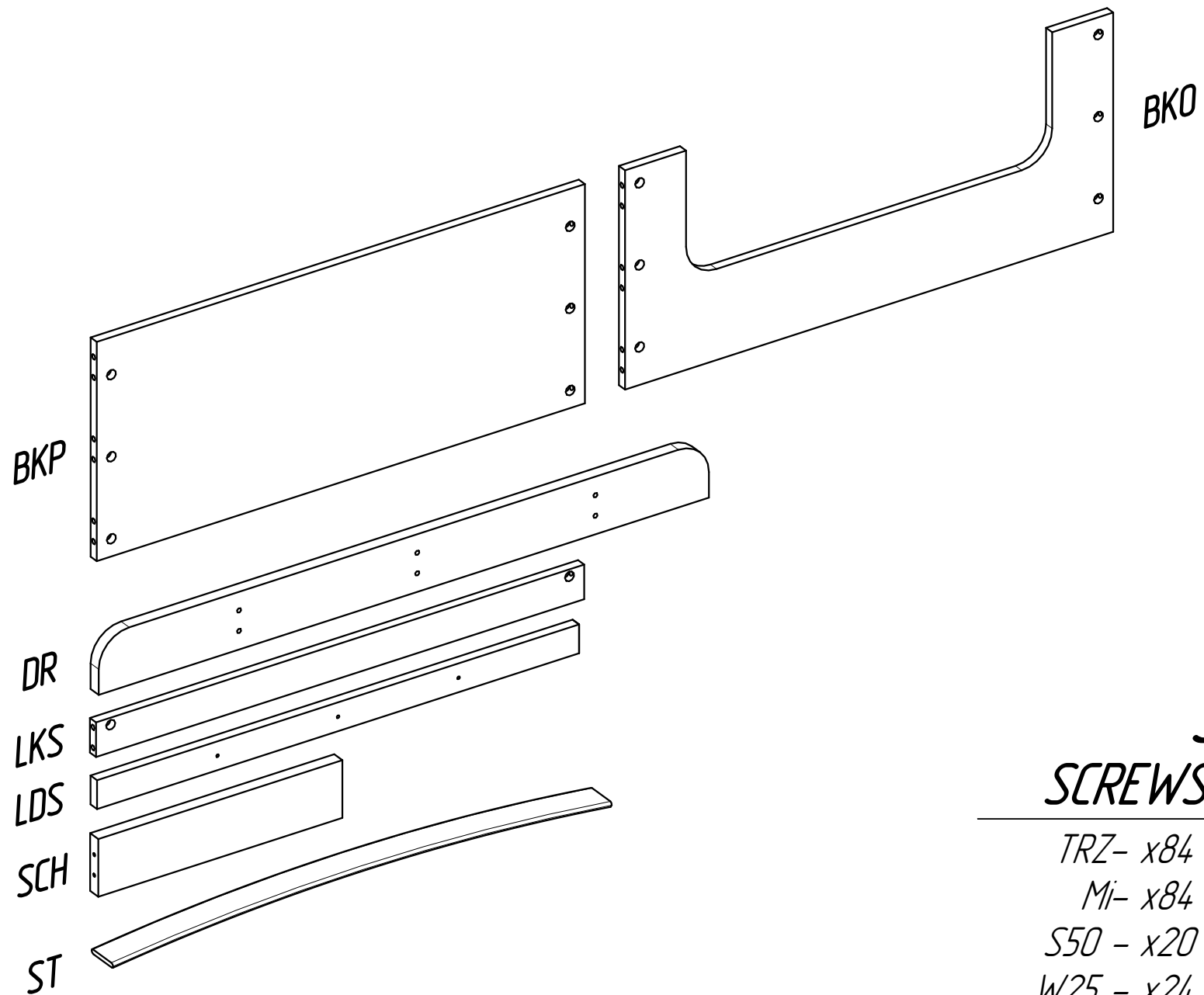

SIMBA

SCREWS	ELEMENTS
TRZ - x84	BKP - x4
Mi - x84	BKO - x4
S50 - x20	DR - x2
W25 - x24	LKS - x6
K8 - x84	LDS - x8
	SCH - x3
	ST - x24-32

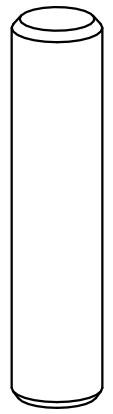
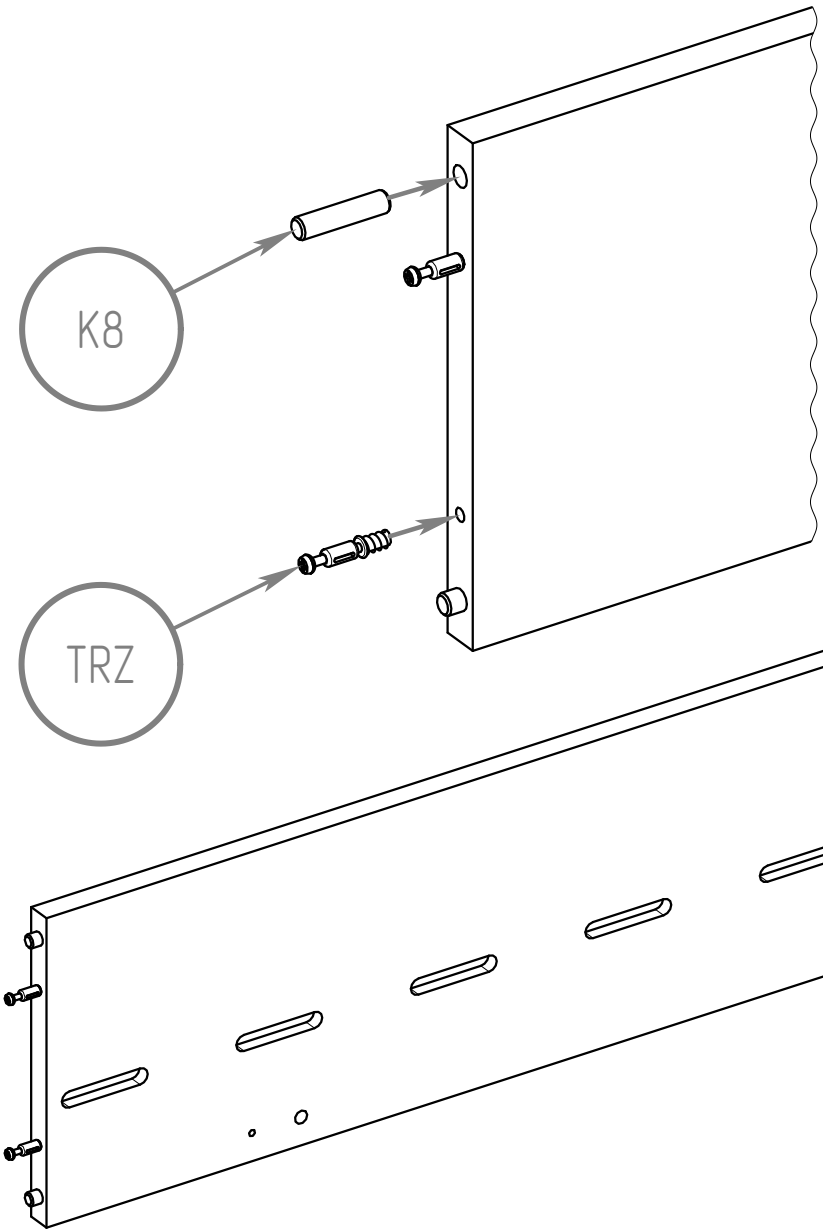

K8 M8X35

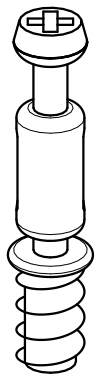

TRZ M5X35



BTD

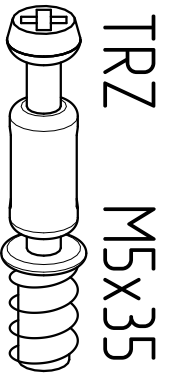

TRZ M5x35

K8 M8x35

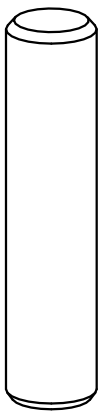

BTG

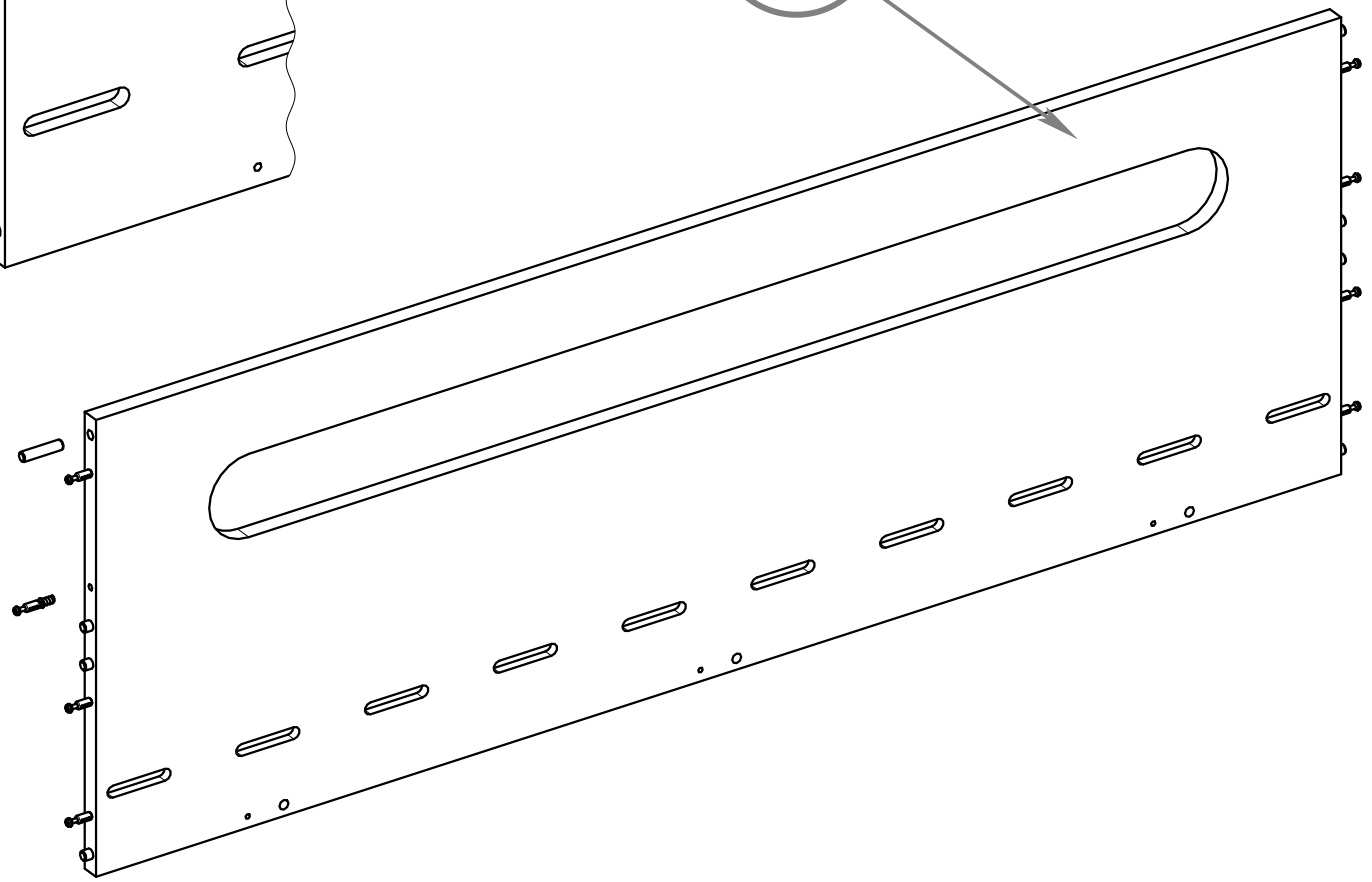

K8

TRZ

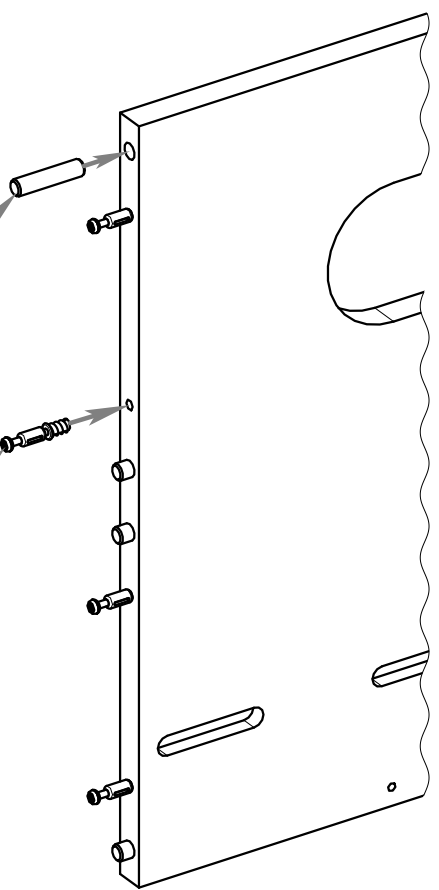

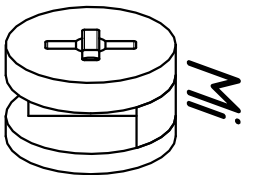
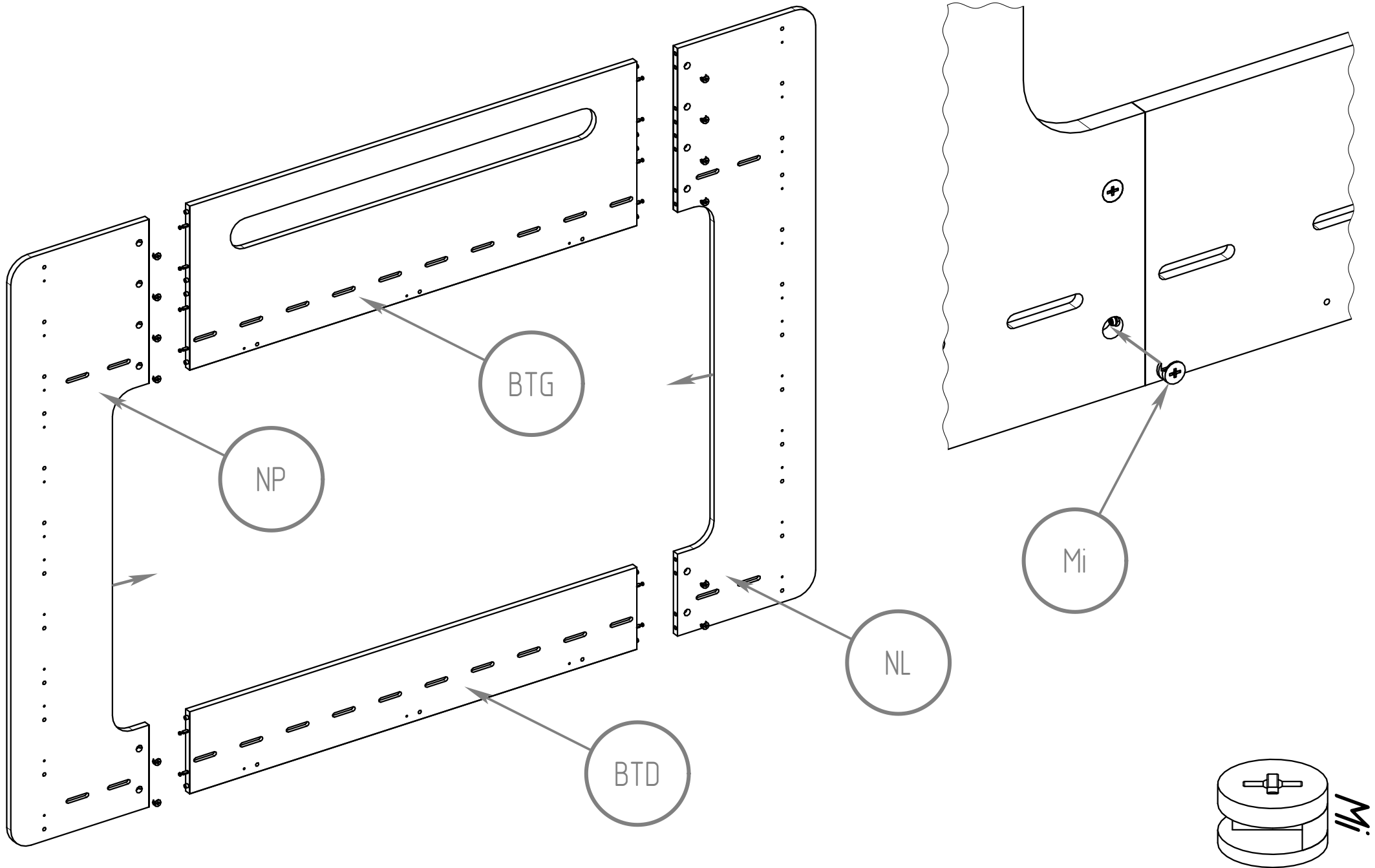

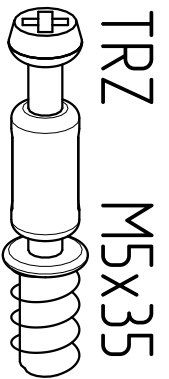

TRZ

M5x35

K8 M8x35

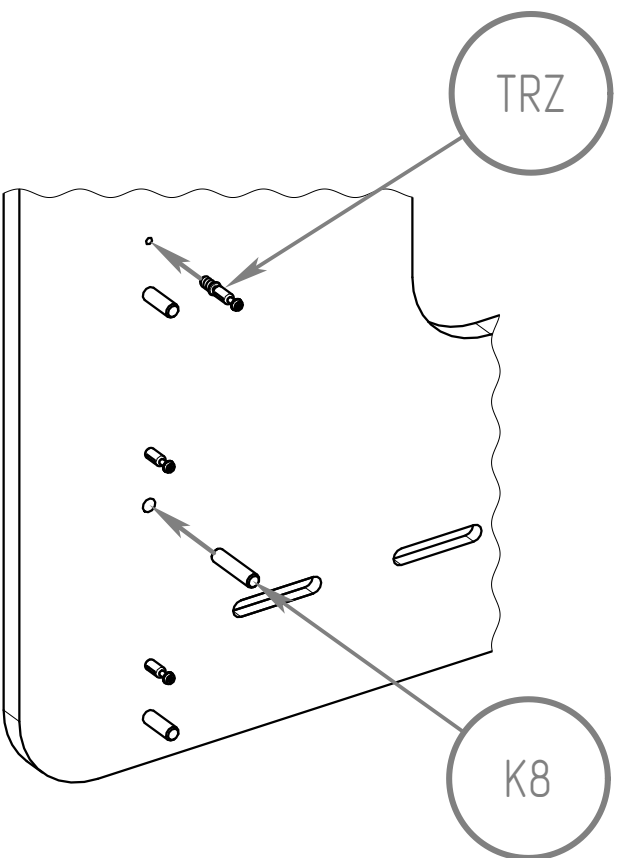
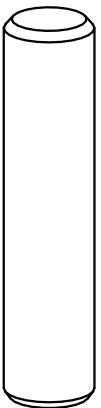

TRZ

K8

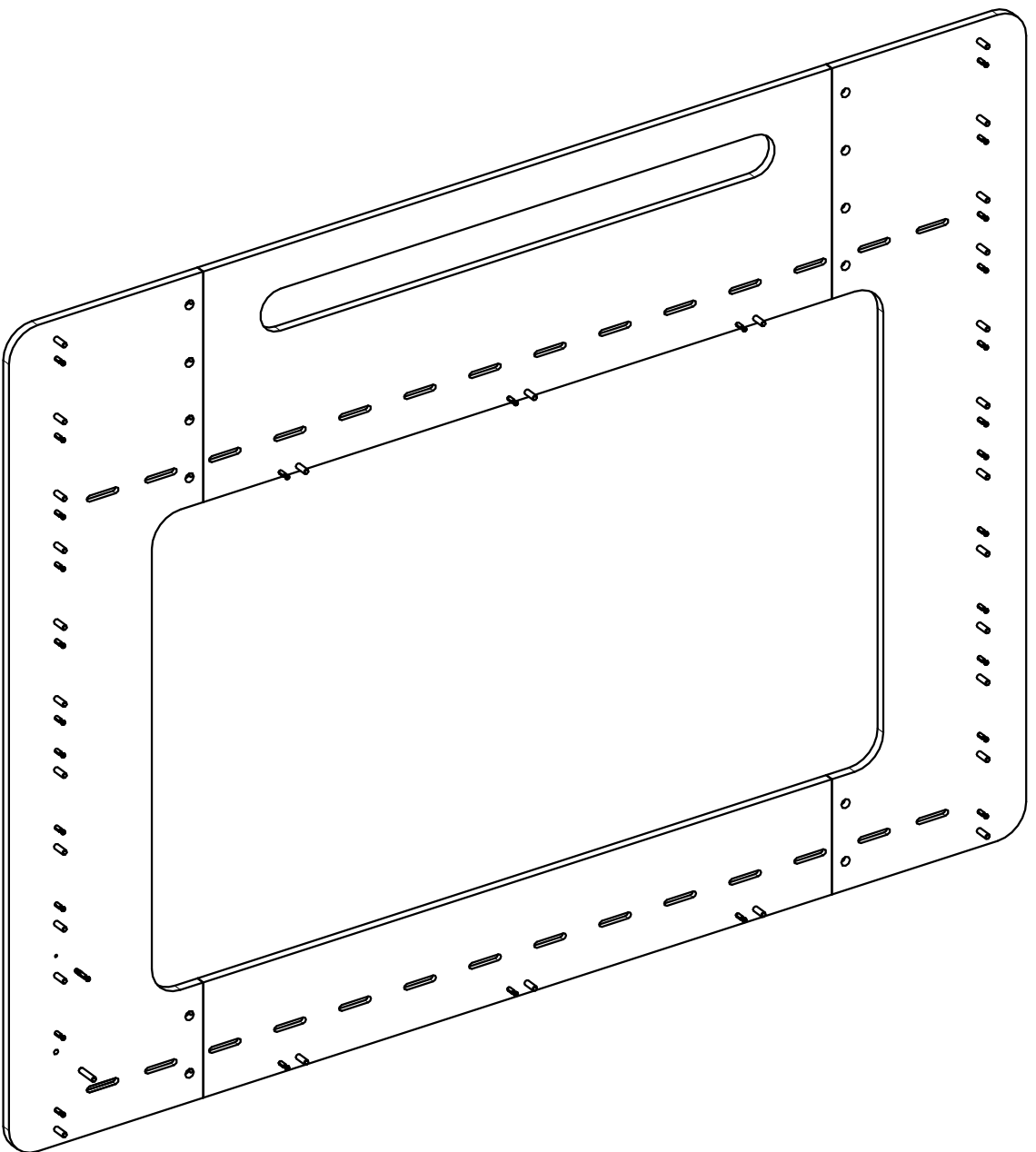

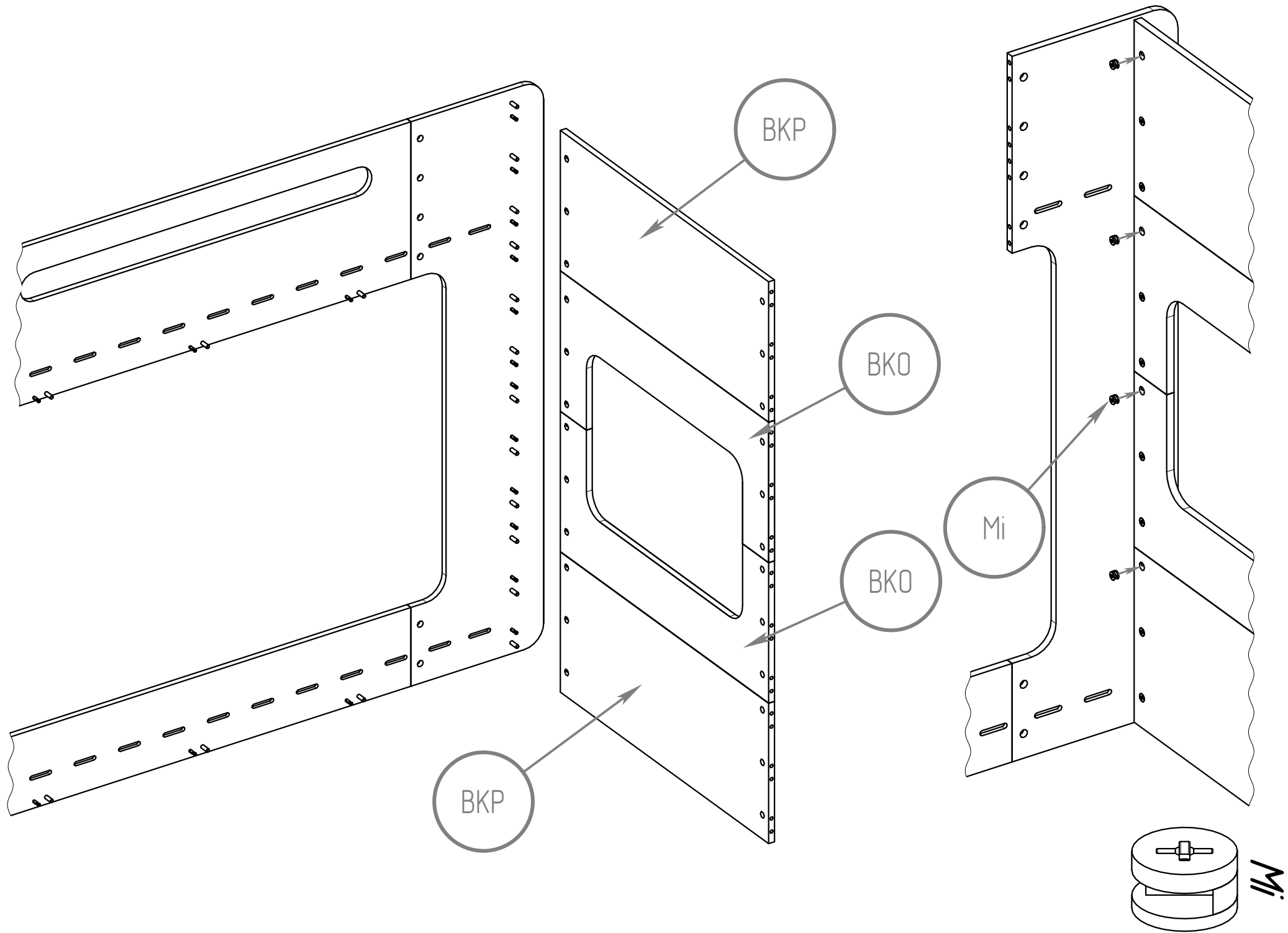

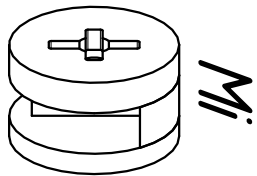
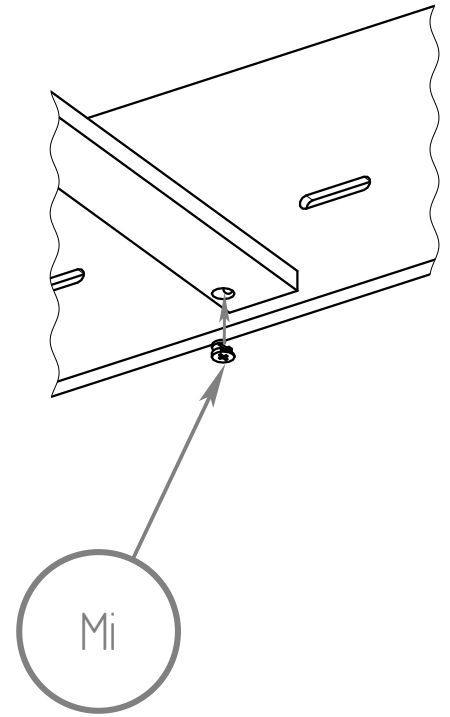
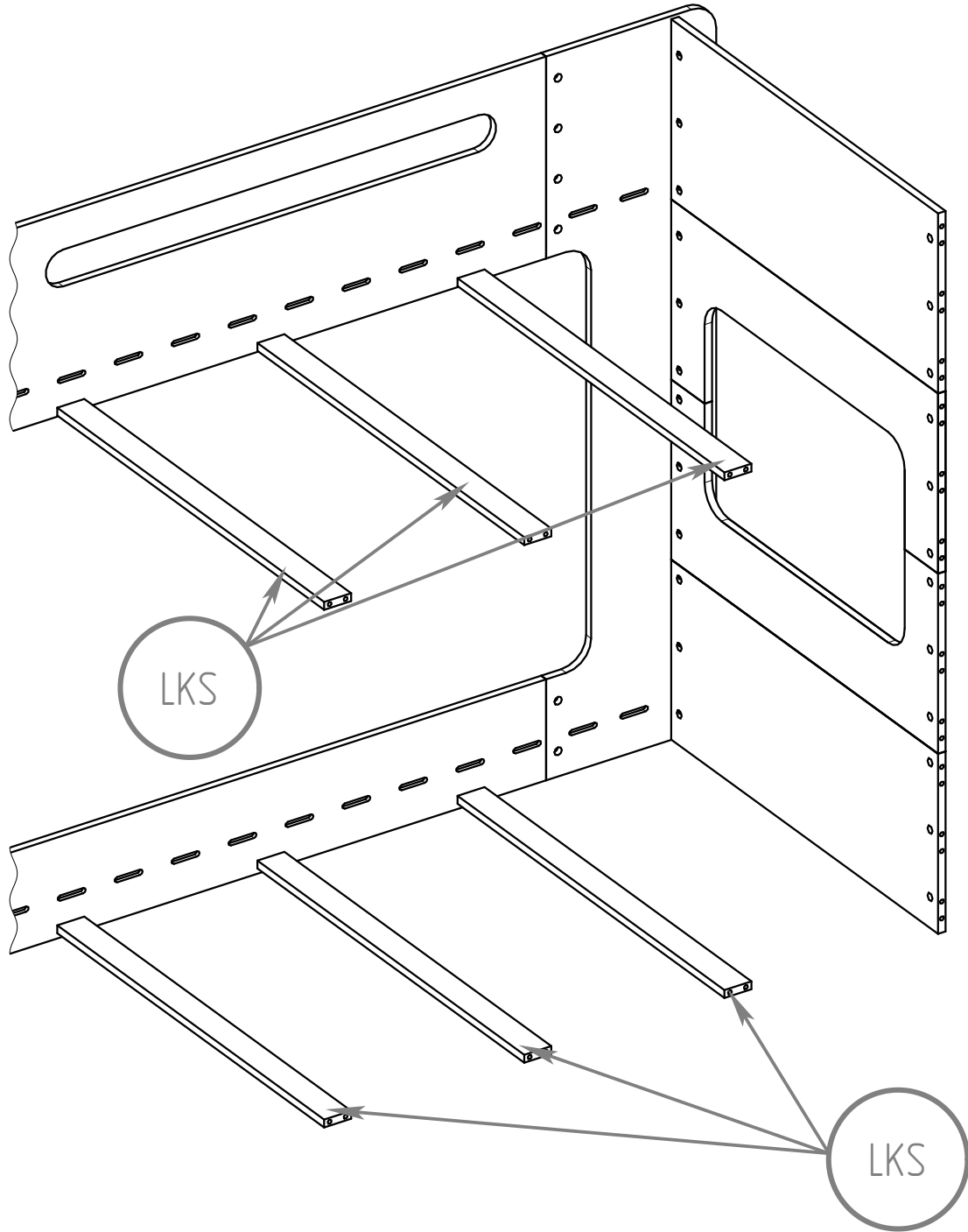

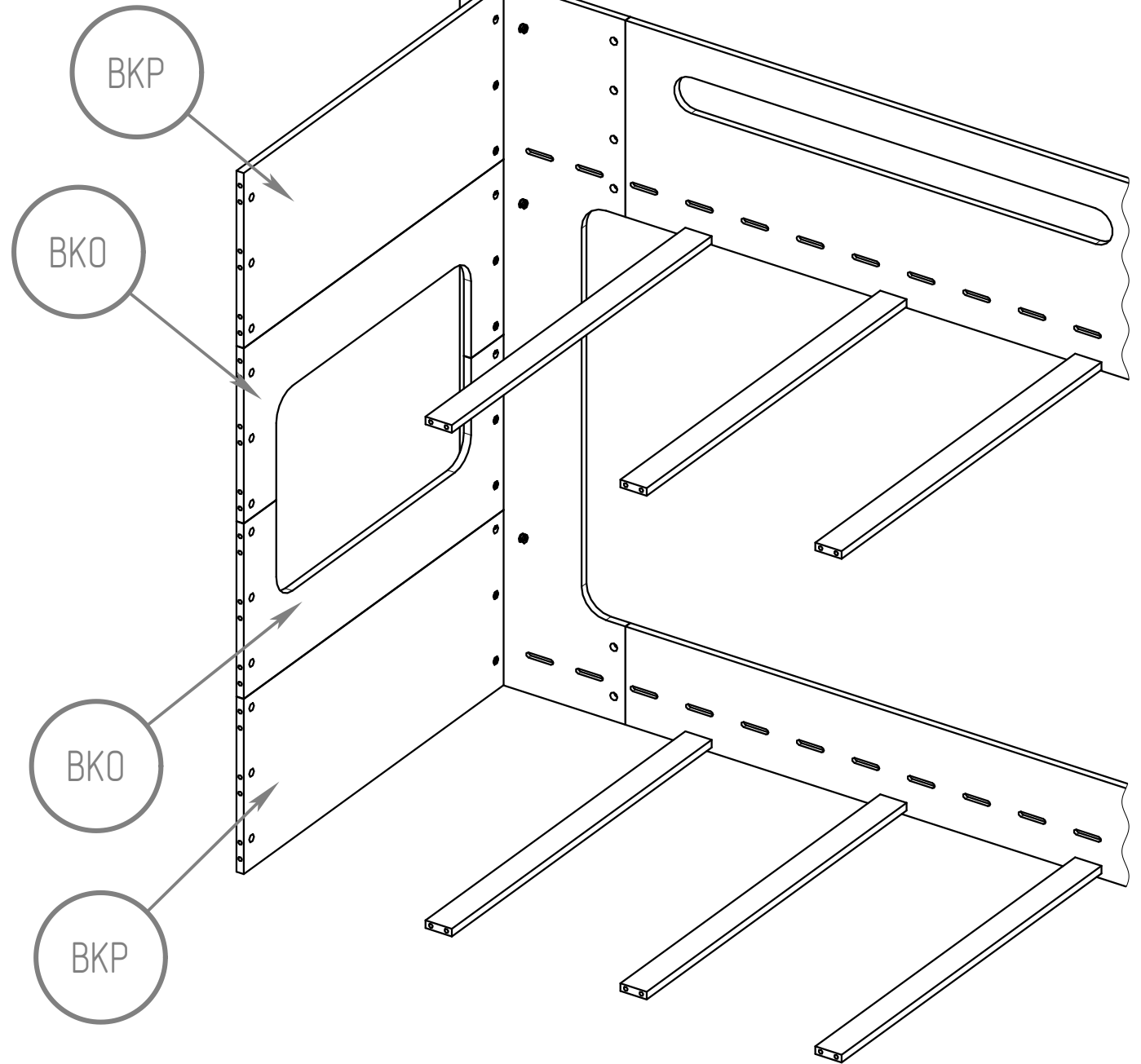
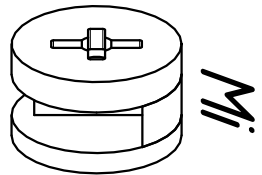
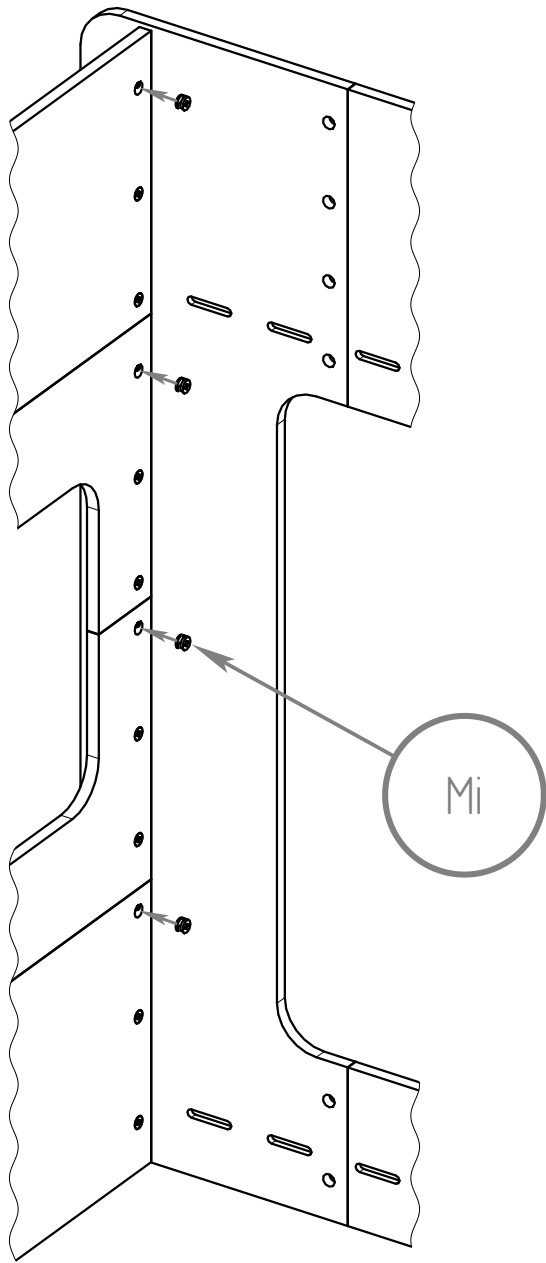

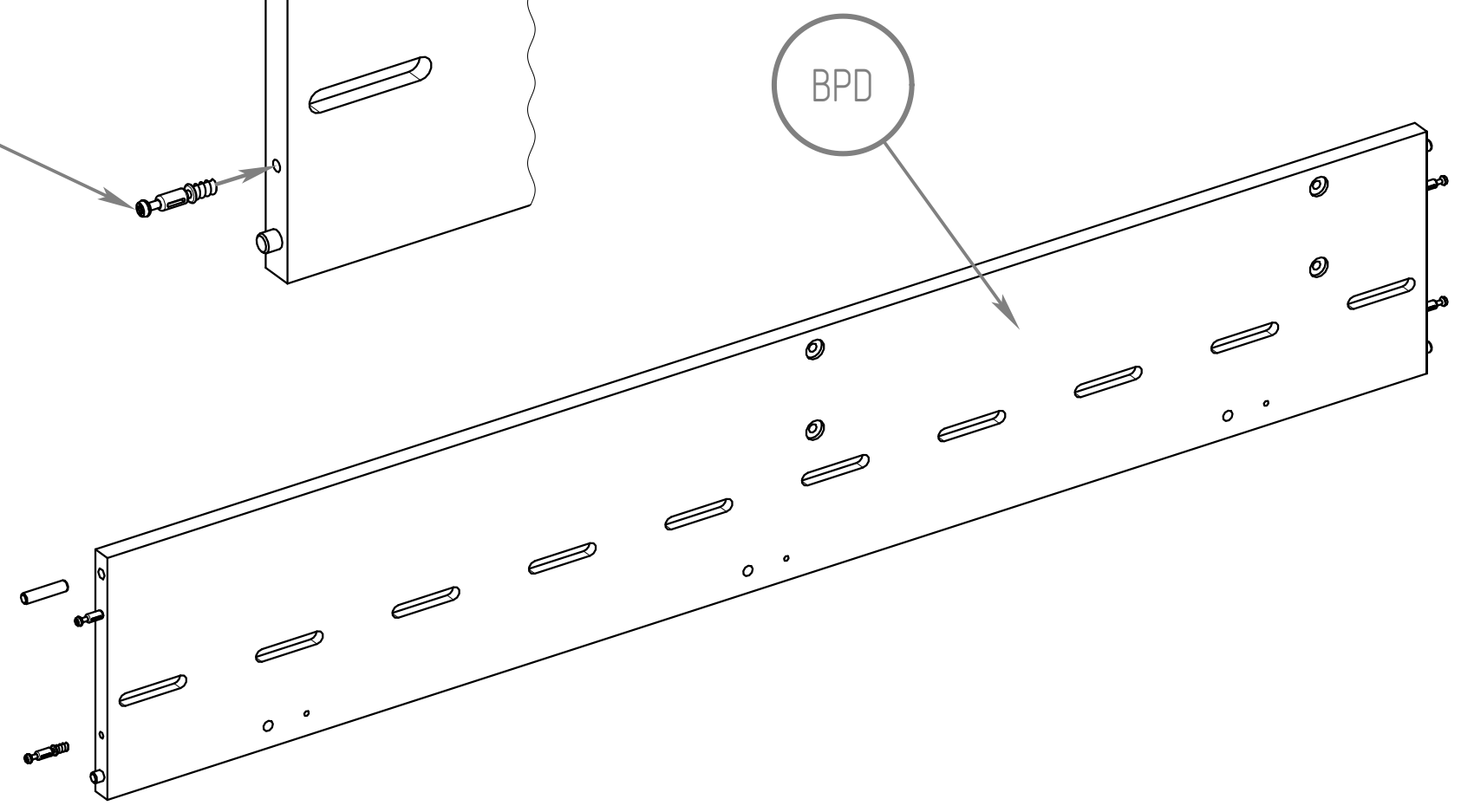
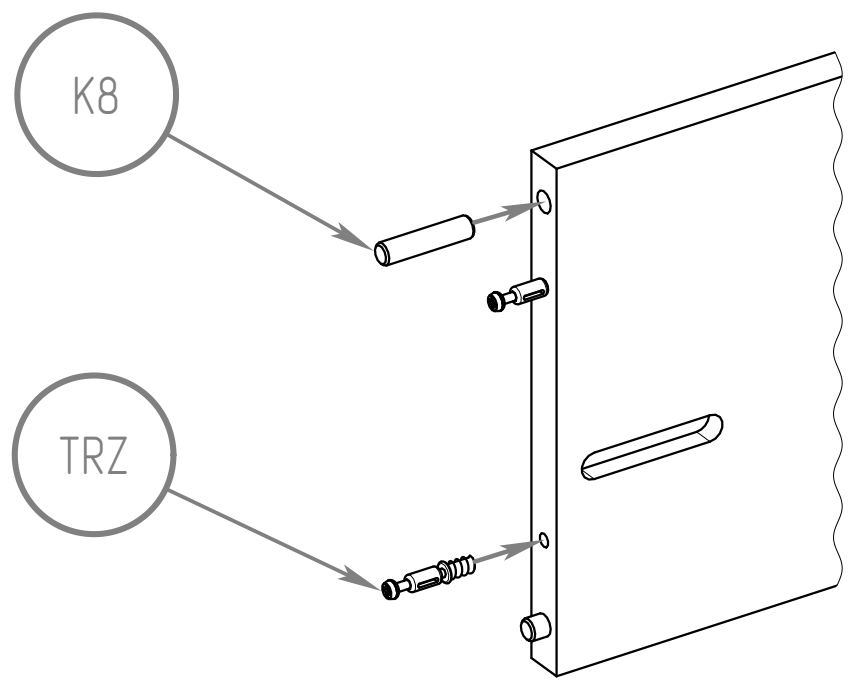
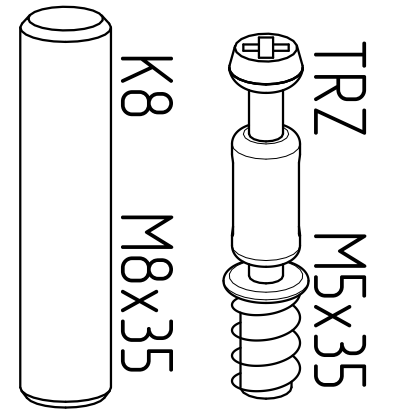

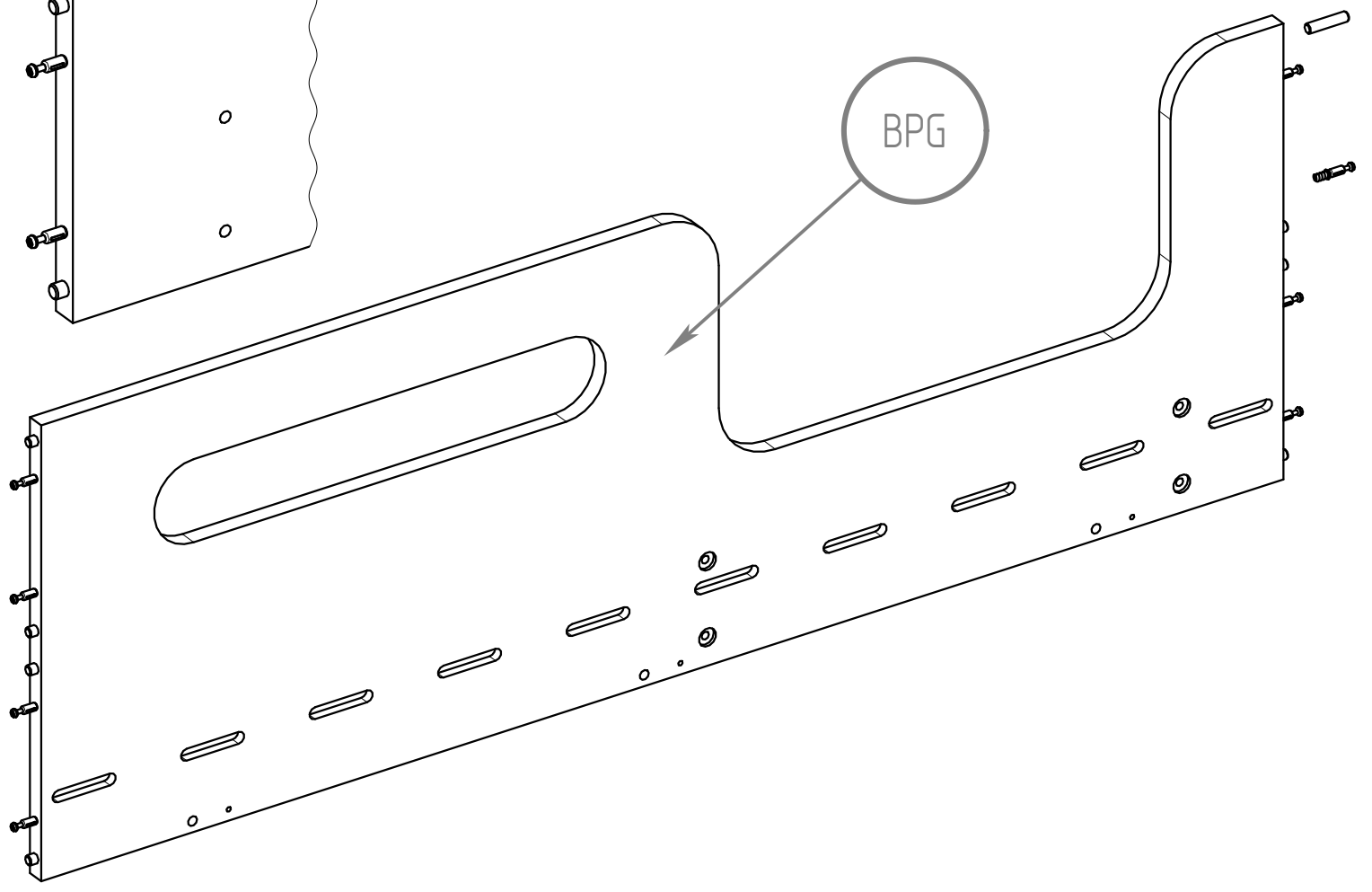
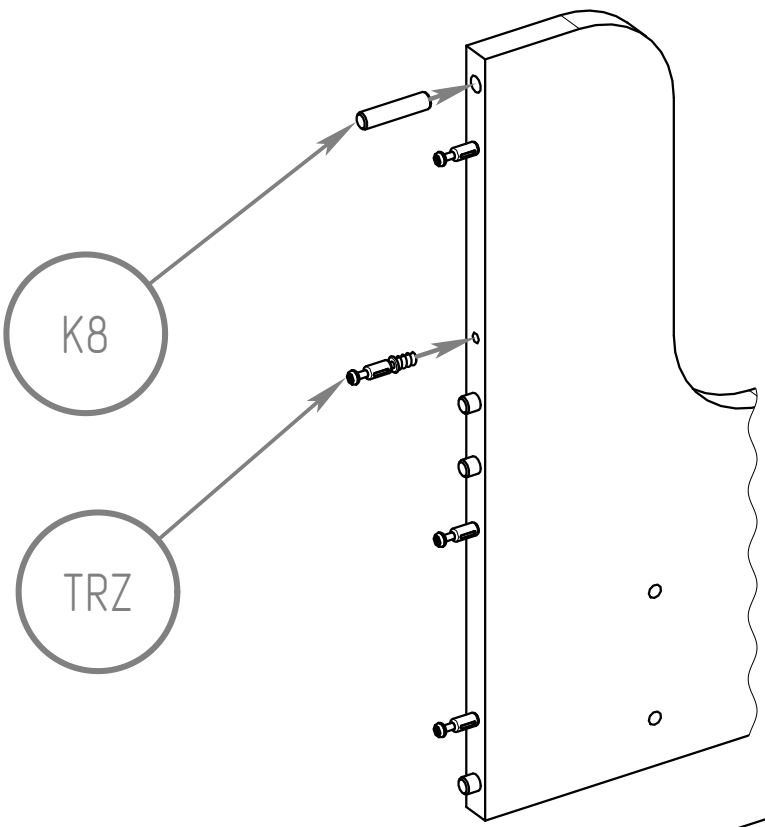
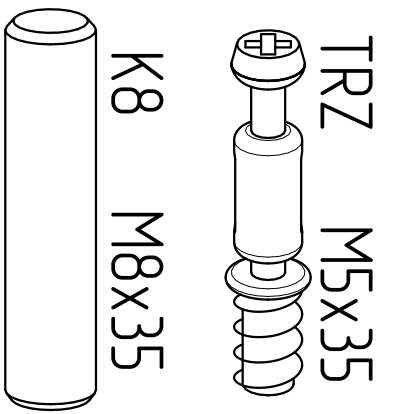

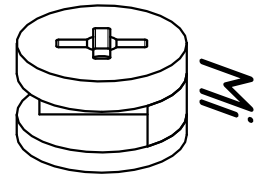
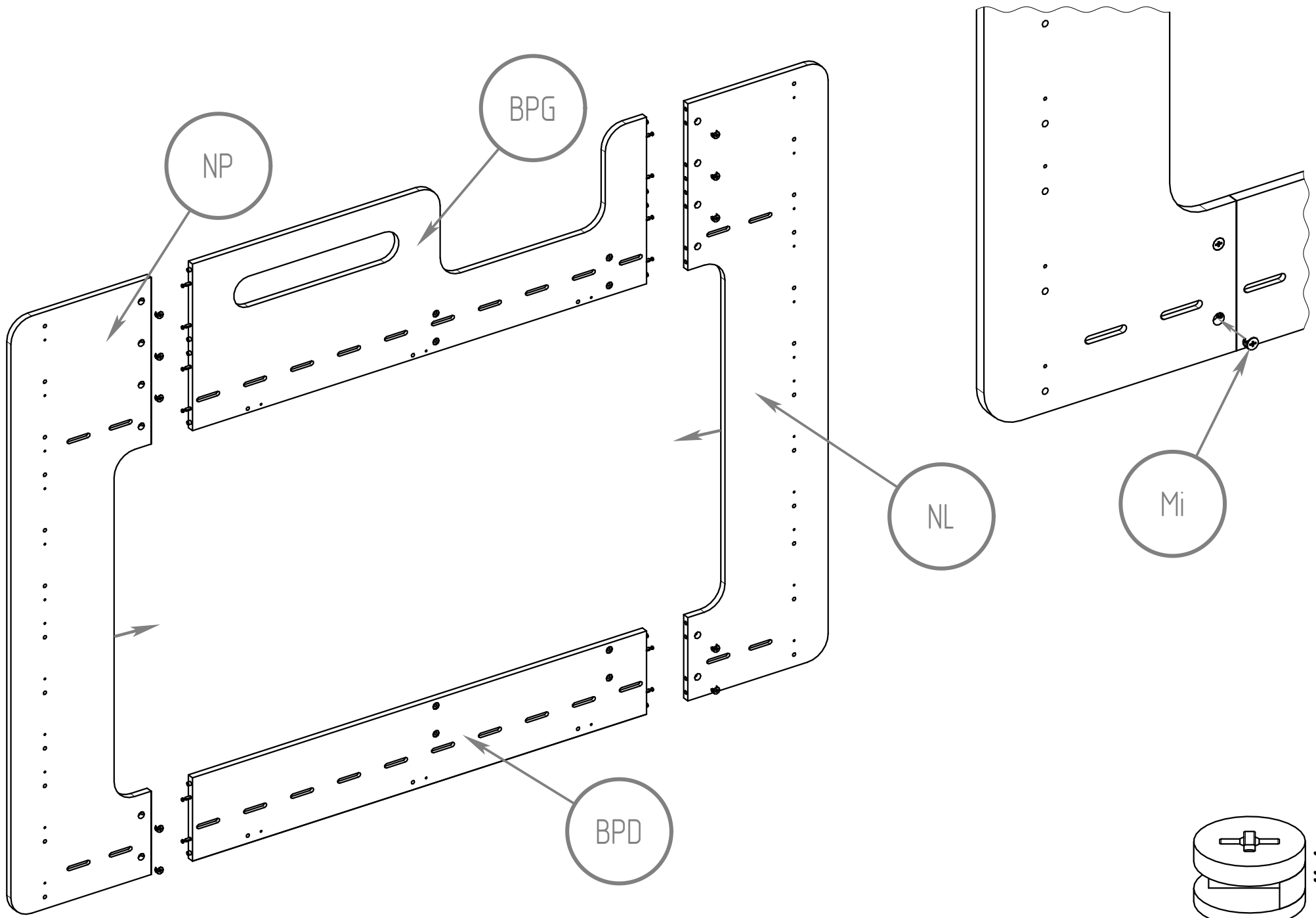

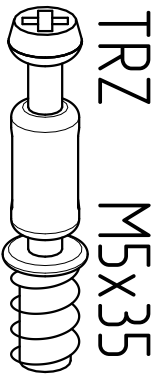

TRZ M5x35

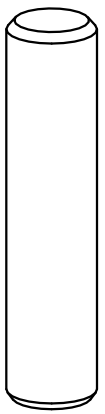

K8 M8x35

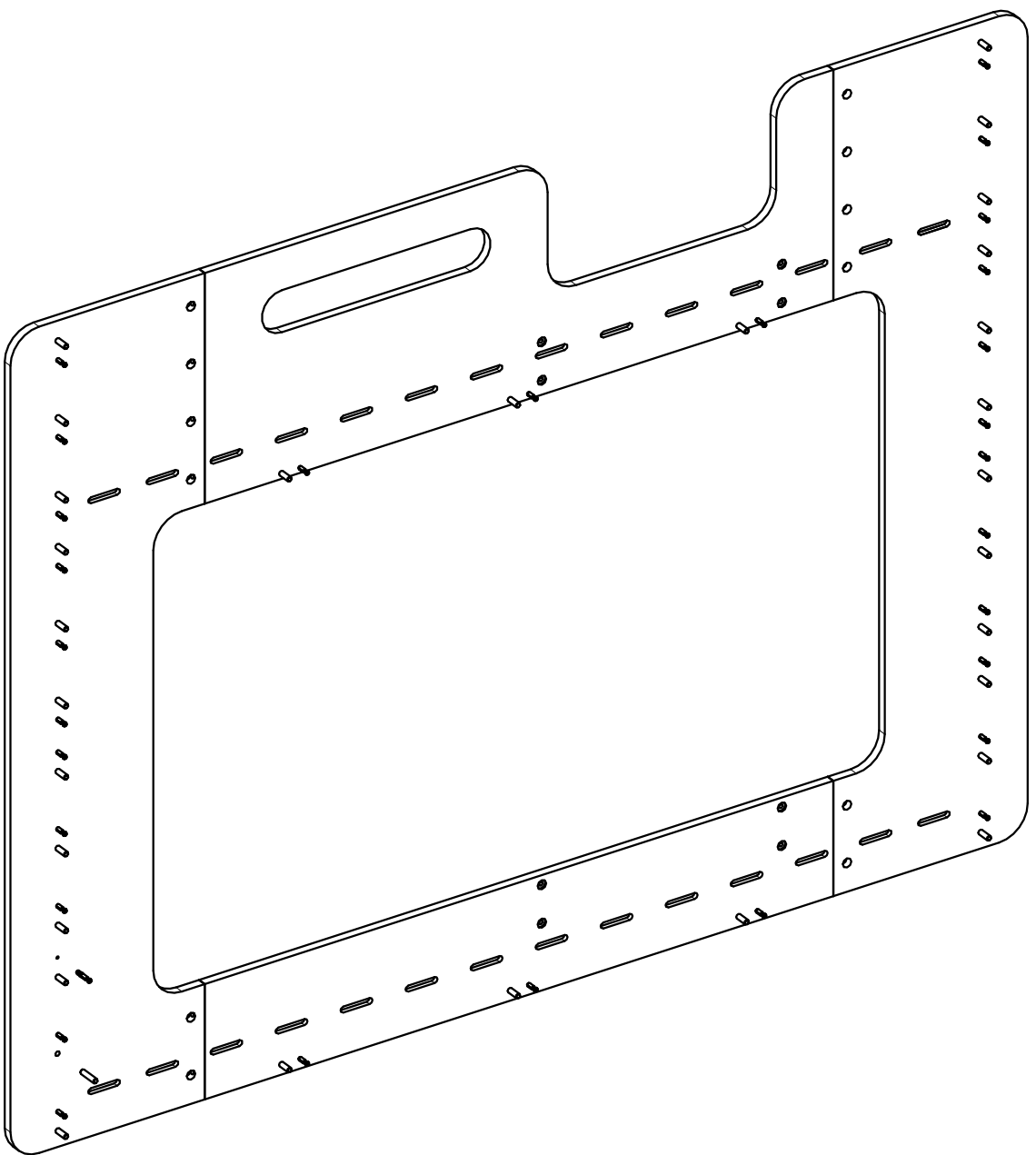
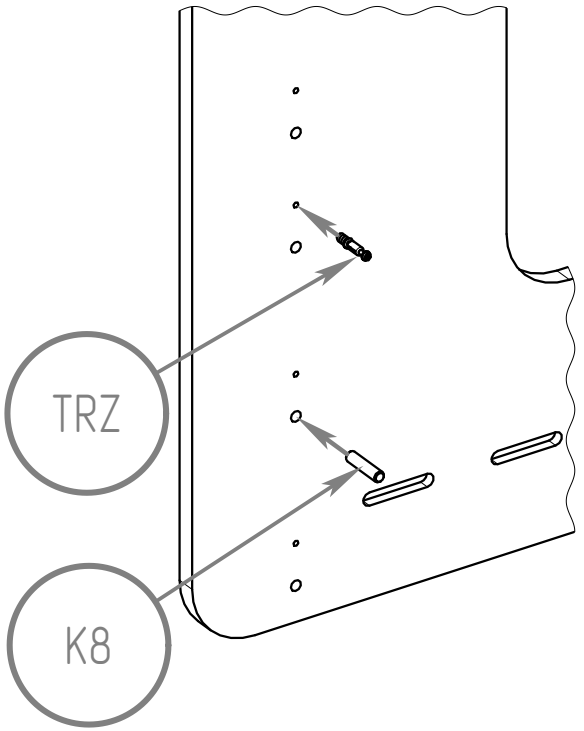

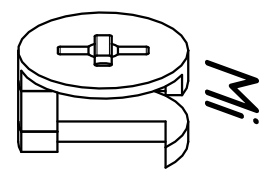
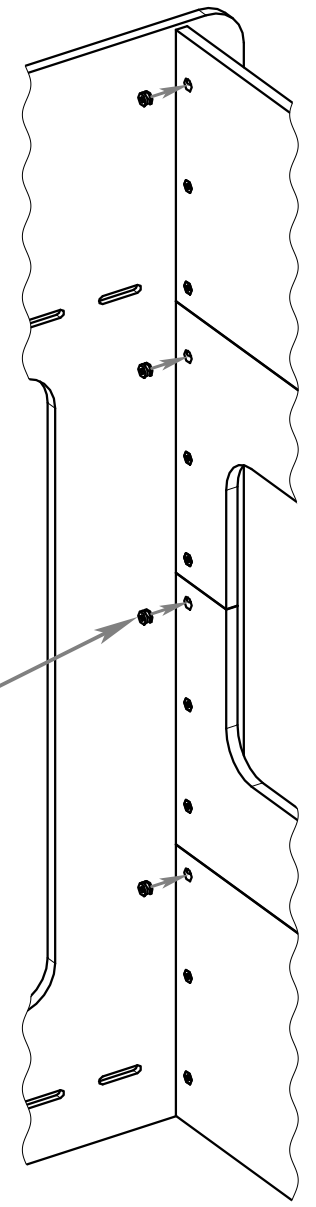
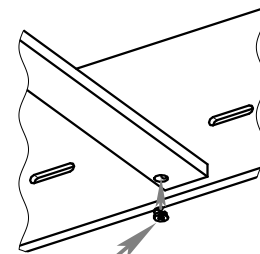
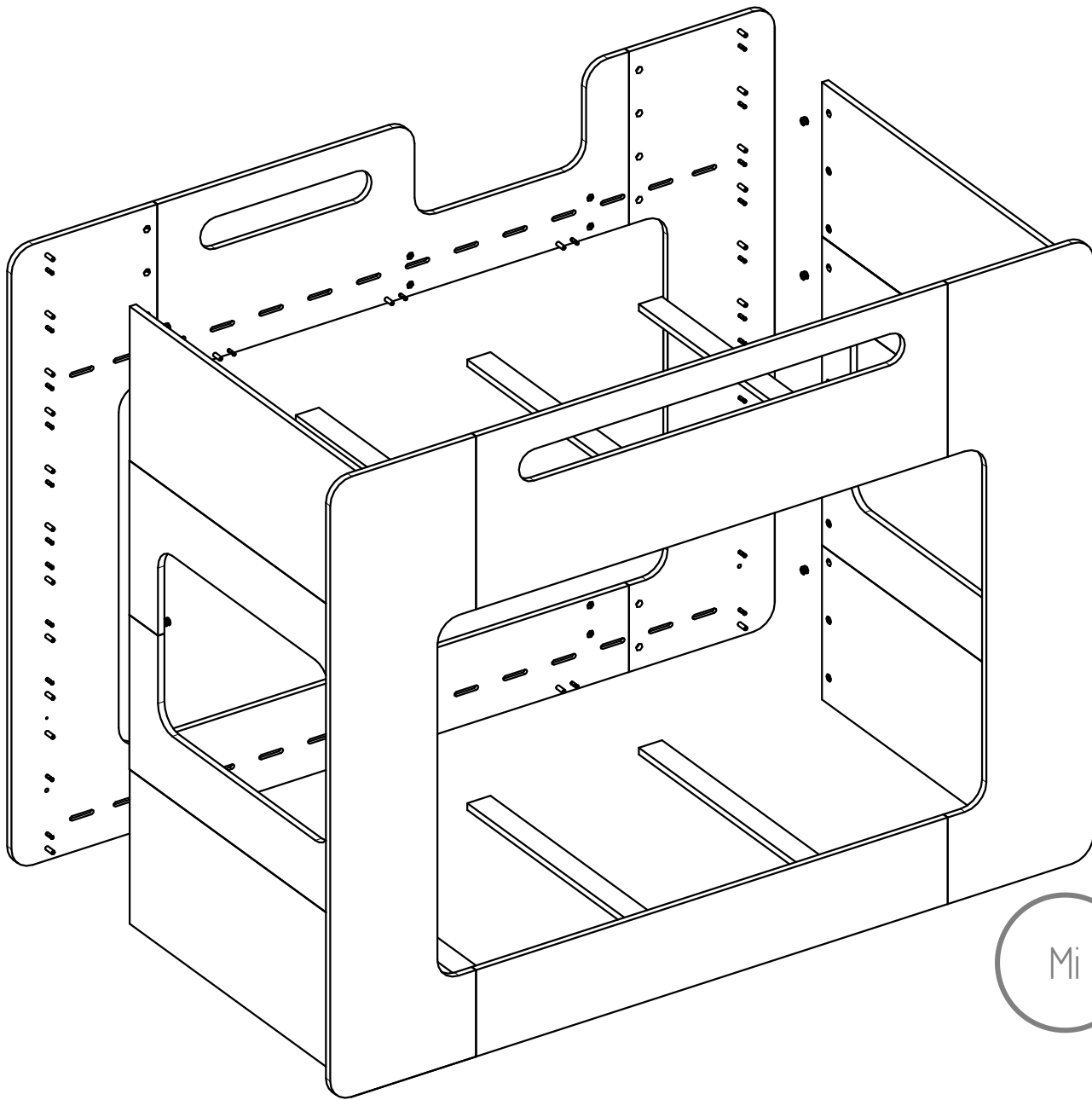

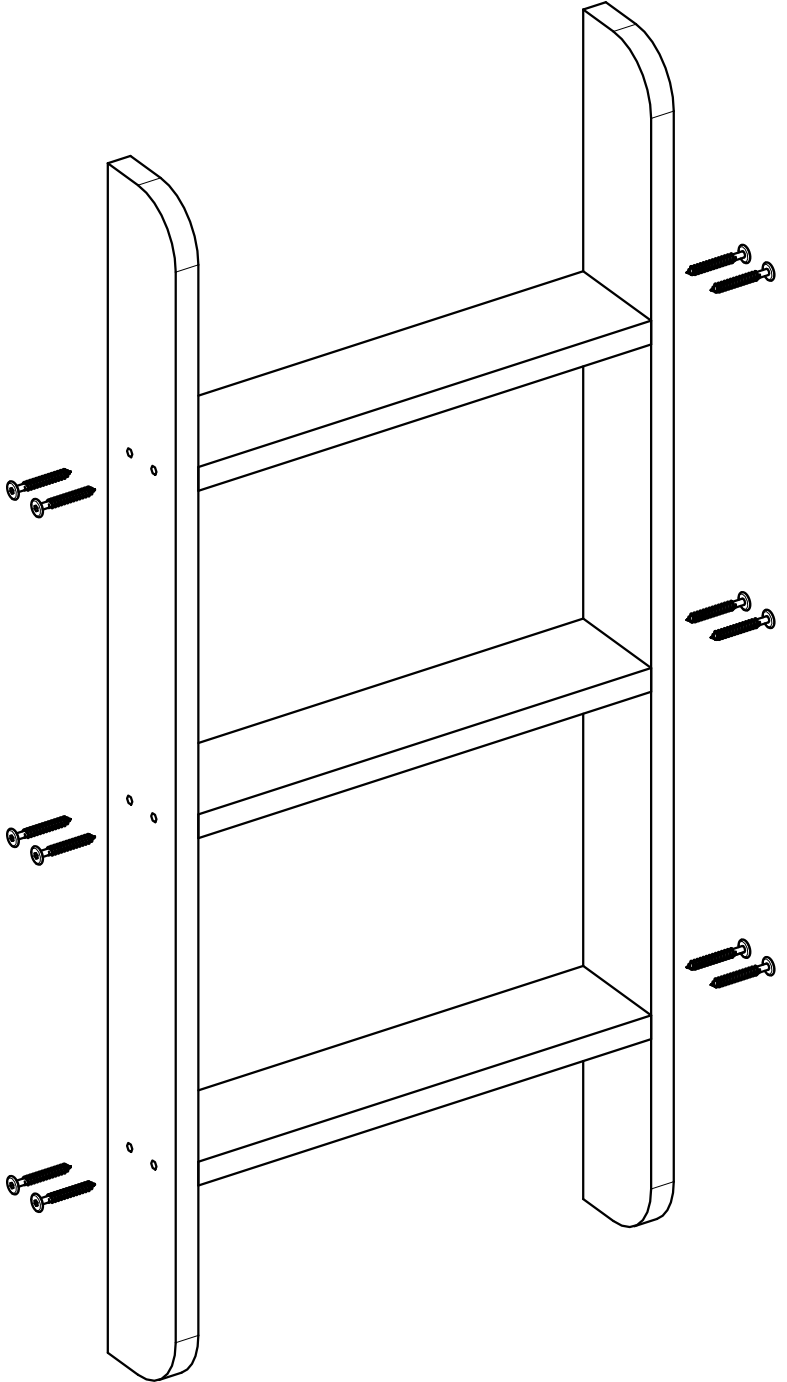

S50

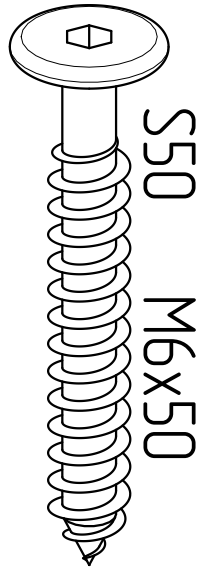
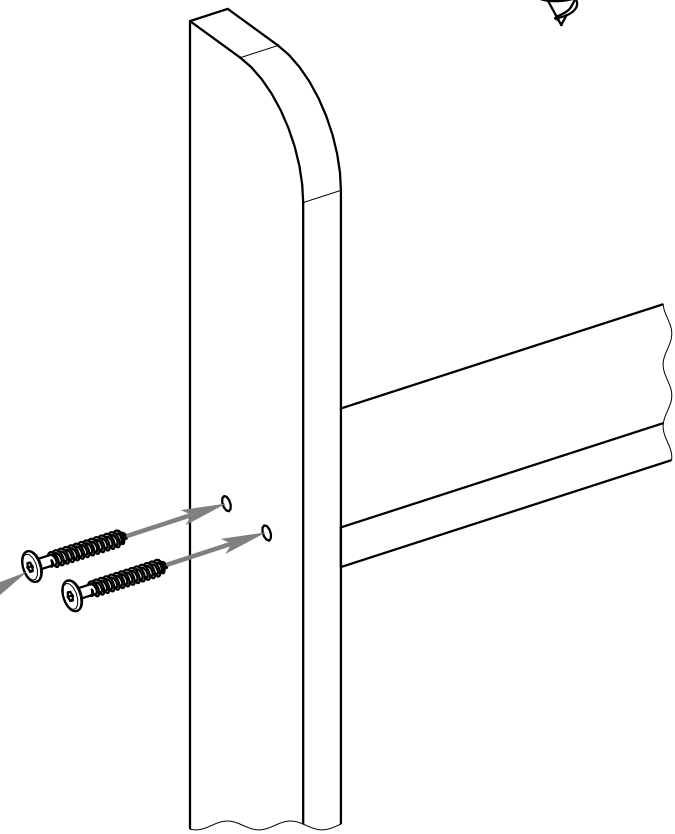

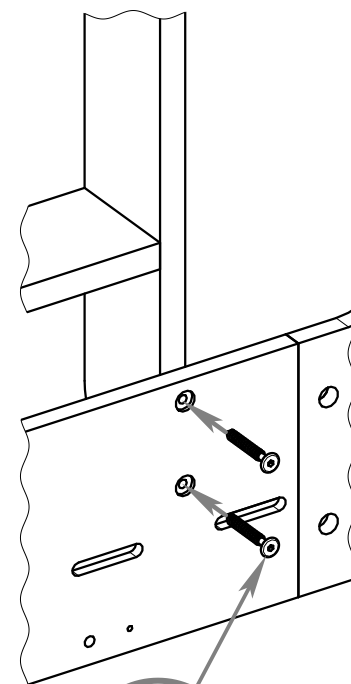
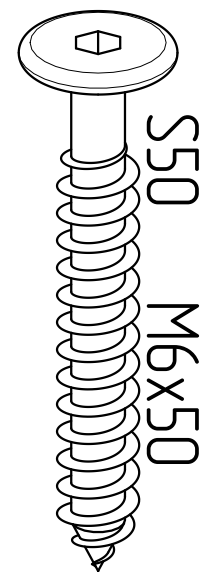
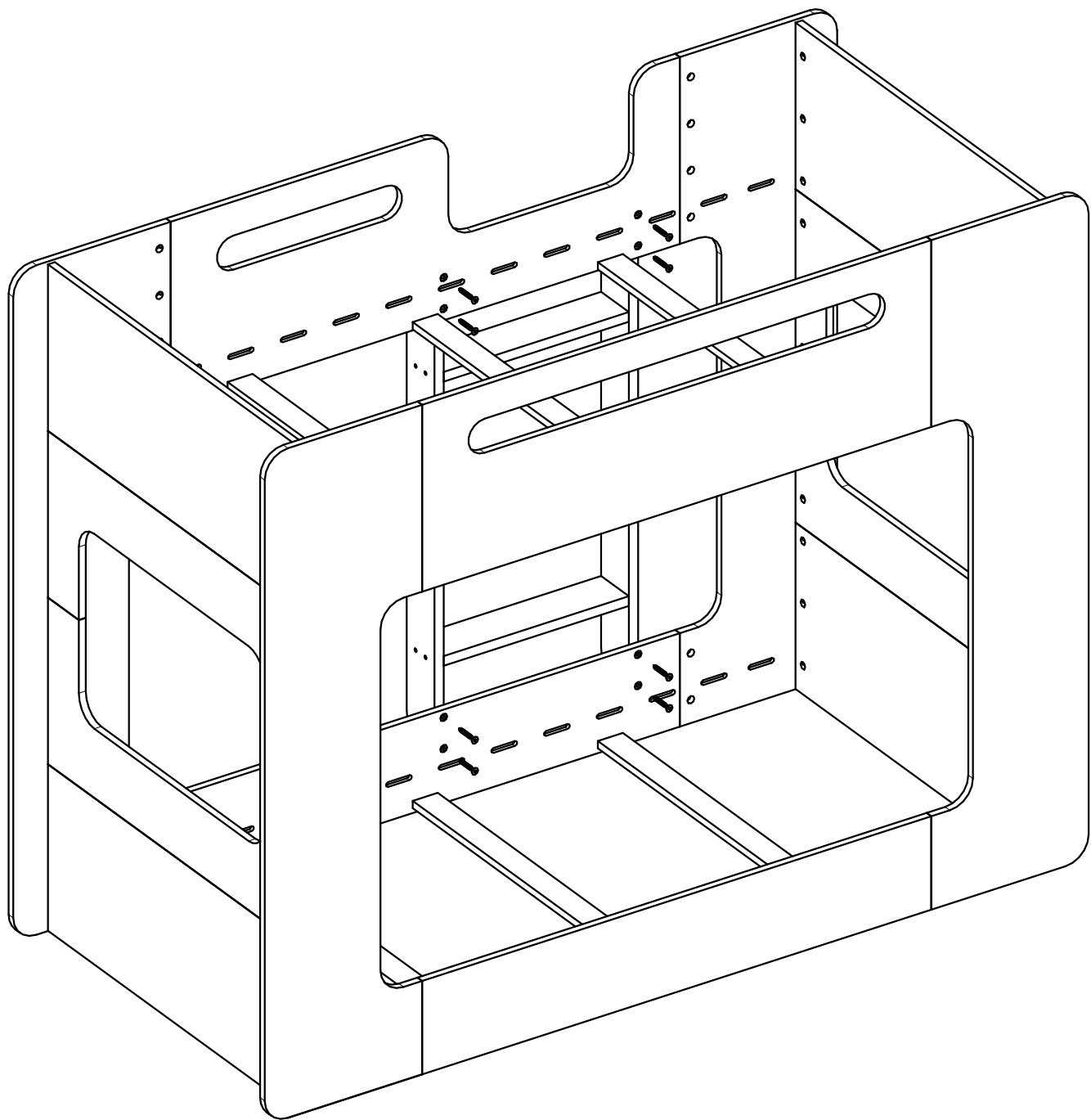

S50

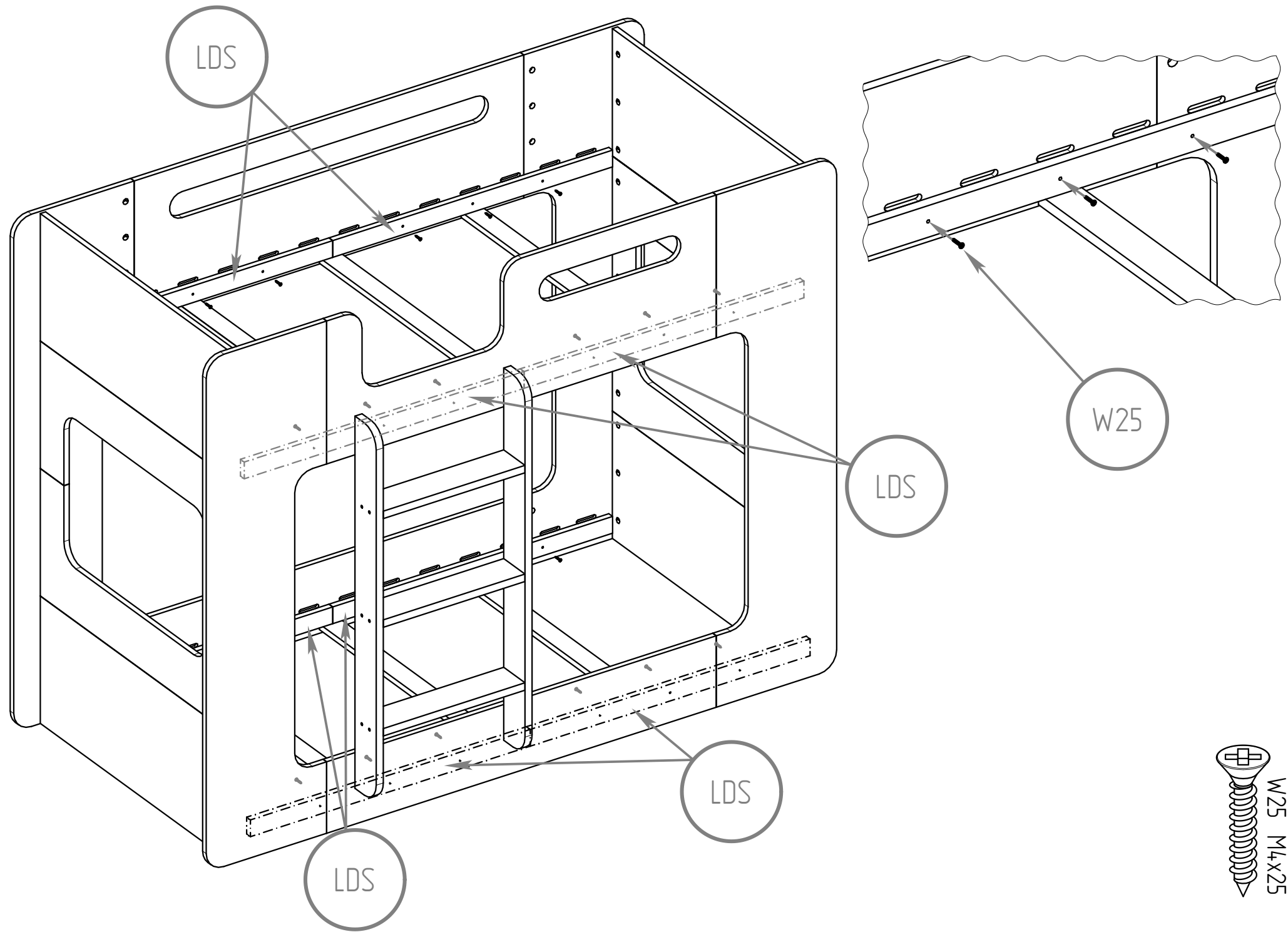

LDS

LDS

W25

LDS

LDS

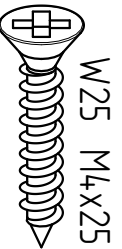

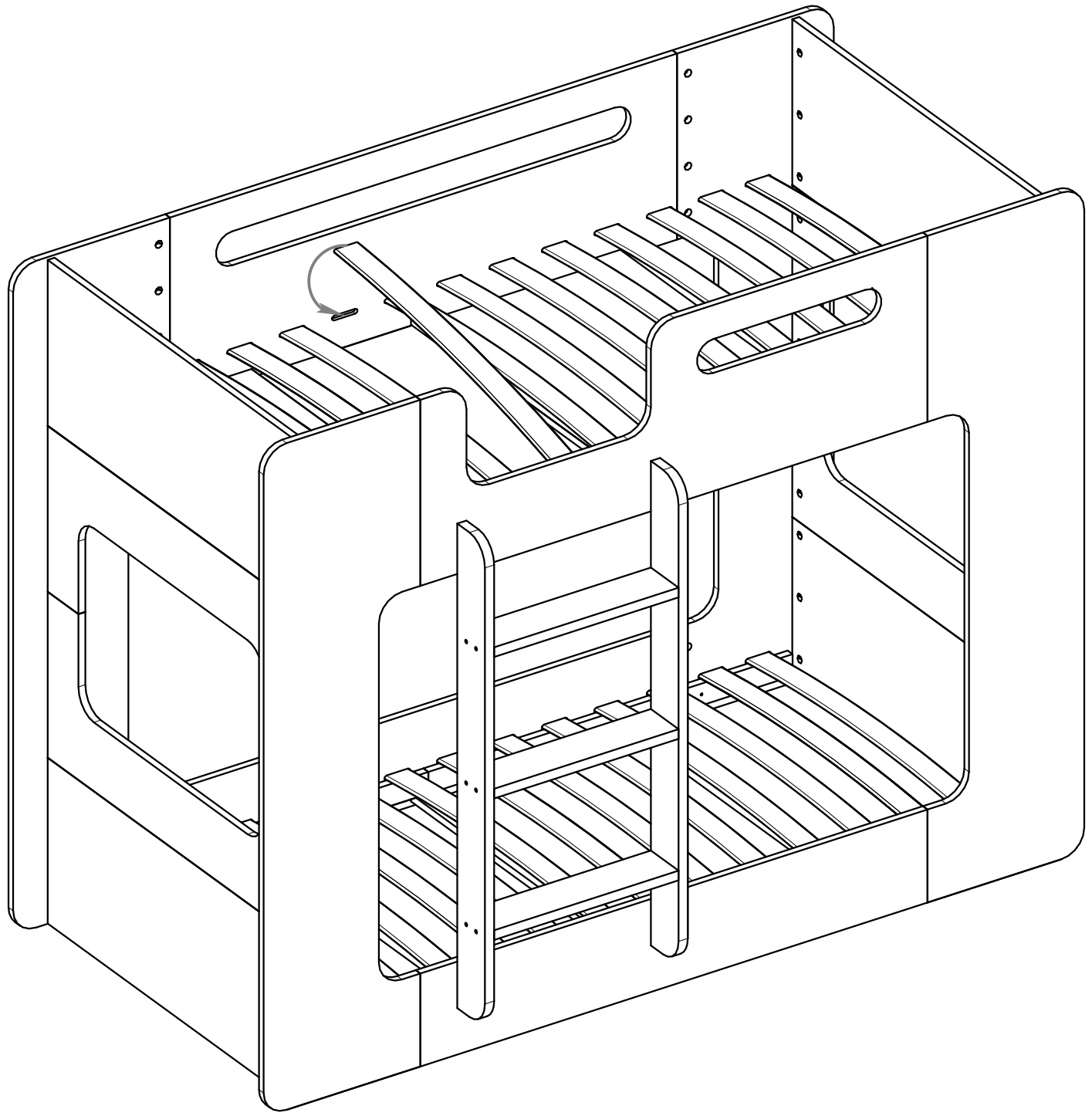



NO JUMPING

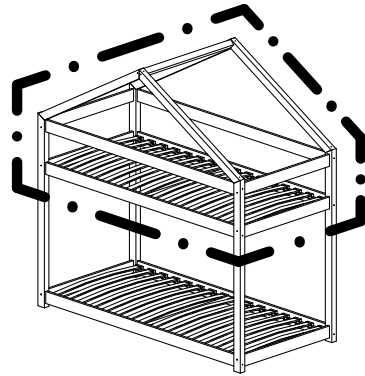

*Upper bed for
children 6+ years old*

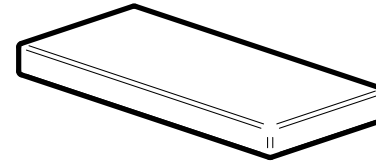

Mattress height:

min. 8 cm

max. 12 cm



WARNING !

- Never allow a child under 6 years on upper bunk.*
- Use only mattress with thickness is 8-12 cm height.*
- Use guardrails on both sides of upper bunk.*
- Prohibit horseplay on or under bed(s).*
- Prohibit more than one person on upper bunk.*
- Use ladder for entering and leaving upper bunk.*

*Designed and made according to the standard:
PN-EN 747-1+A1:2015-08*

*STRANGULATION HAZARD - Never attach or hang
items to any part of the bunk bed that are not
designed for use with the bed.*

*Wooden and plastic parts should be cleaned with a
dry cloth and ordinary, mild care and cleaning of raw
wood.*

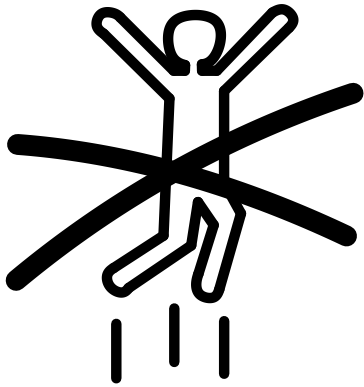

NIE SKAKAĆ

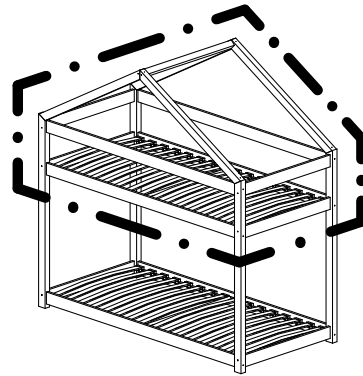

*Górne tóżko dla dzieci
powyżej 6 roku życia.*

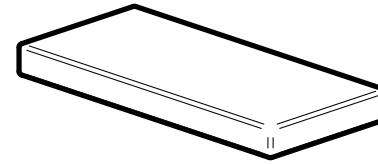

Wysokość materaca:

min. 8 cm

max. 12 cm



UWAGA !

- Nigdy nie pozwalać dzieciom poniżej 6 roku życia przebywać na górnej pryczy.*
- Używać tylko materacy o grubości 8-12 cm.*
- Używać poręczy po obu stronach górnej pryczy.*
- Nie skakać na lub pod tóżkiem (tóżkach).*
- Zakazywać przebywania więcej niż jednej osoby na górnym tóżku.*
- Używać drabiny, aby wejść i wyjść z górnej pryczy.*
- Nie wieszać się na elementach konstrukcyjnych.*

Części drewniane i plastikowe należy czyścić za pomocą suchej szmatki oraz zwykłych, łagodnych środków do pielęgnacji i czyszczenia surowego drewna.

*Zaprojektowano i wykonano zgodnie z normą:
PN-EN 747-1+A1:2015-08*

NIEBEZPIECZEŃSTWO ZAGROŻENIA – Nigdy nie podłączaj ani nie zawieszaj przedmiotów do jakiegokolwiek części tóżka piętrowego, do której nie są przeznaczone.